

NO 4

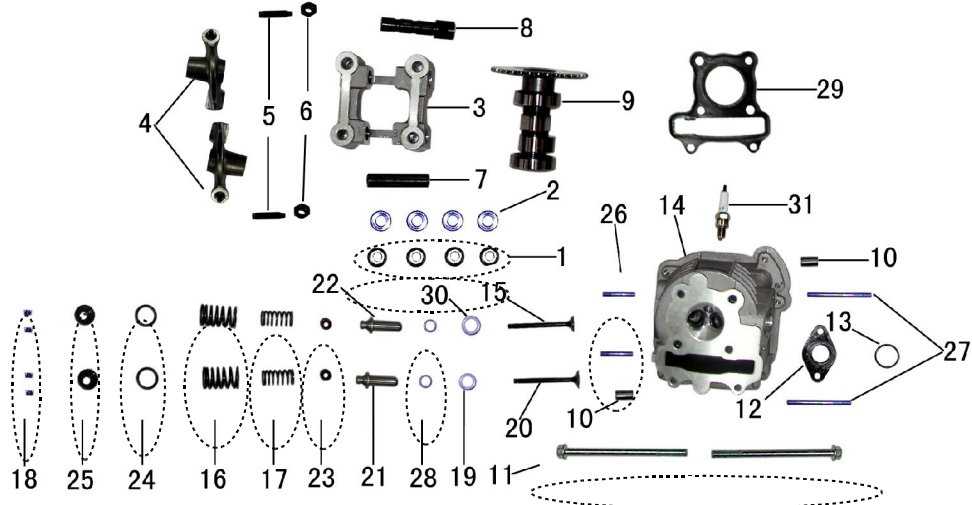

No.	Part no.	Description in English	Qty
1	220001	Hexagon nut M7	4
2	220002	Washer $\Phi 7 \times 14$	4
3	220003	Retainer, valve rocker	1
4	220004	Arm, Valve rocker	2
5	220005	Screw, lappet adjusting	2
6	220006	Lock nut	2
7	220007	In valve rocker axis	1
8	220008	Out valve rocker axis	1
9	220009	Camshaft	1
10	220010	pin $\Phi 8 \times 14$	2
11	220011	Hexagon screw M6 \times 85	2
12	220012	Heat insulation plate	1
13	220013	Mat of heat insulation	1

NO 5

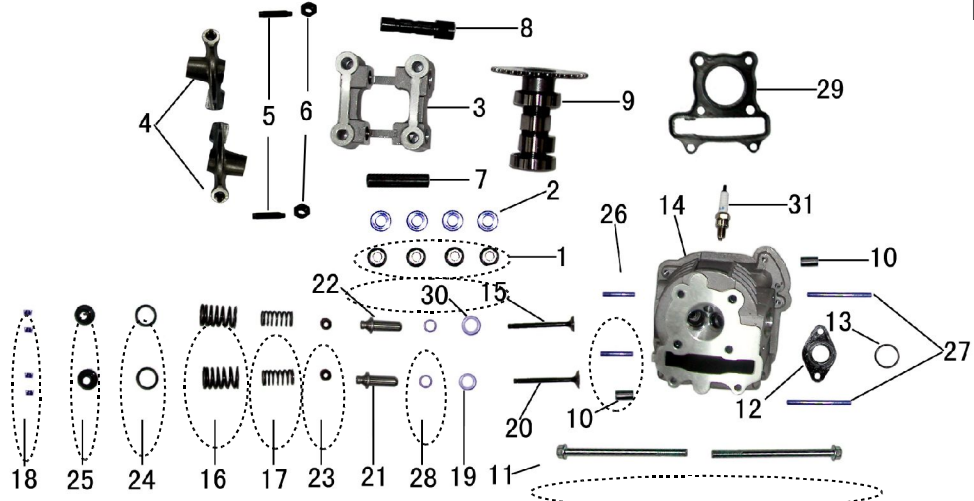

No.	Part no.	Description in English	Qty
14	220014	Cylinder head	1
15	220015	Exit valve	1
16	220016	Valve spring big	2
17	220017	Valve spring small	2
18	220018	Cotter, valve	4
19	220019	Spring holding	1
20	220020	In valve	1
21	220021	In valve leader	1
22	220022	Out valve leader	1
23	220023	Oil seals	2
24	220024	Washer	2
25	220025	Retainer, valve spring	2
26	220026	Bolt stud M6×32	2

